

GEM/GEM2

Installation, Operation, and Maintenance Manual





Table of Contents





Safety Instructions	3
Flow Meter Specifications	7
Meter Dimensions.....	8
Features	9
Transportation	9
Storage	9
Installation	10
Pressure Drop	10
Operating Range & Accuracy	10
Meter Positioning	11
Straight Pipe Recommendations.....	12
Grounding	13
Chemical Injection Applications.....	14
Drinking Water Applications	14
Wiring GEM Power / Output Cable	15
Wiring Configurations	16
Commonly Used Telemetry/Display Devices	18
Wiring Terminals (Digital Output).....	18
K Factor Settings	18
Modbus Registers	18
Operations	23
Vibrations.....	23
Power Supply	23
Bluetooth App	23
User Interface	24
Available Display Units.....	25
Flow Totalizer Display Format.....	25
Flow Rate Display Format	26
Troubleshooting Guide	28
PCB & Battery Replacement	28
Troubleshooting Summary	31
Accessories and Spare Parts	32
Revision Table	32
Appendix - Limited Warranty Statement	33

Safety Instructions



WARNING

Personal Safety: Throughout this manual and on all safety signs, the precautionary statements (“**DANGER**”, “**WARNING**”, “**CAUTION**” and “**NOTICE**”) can be found, followed by a hazard description and preventative actions to be taken. These precautions are intended for the personal safety of the operator and those within the vicinity of the machinery. Please take time to read these precautions.

Hazard Severity Panels			
Background Color of Panel	Contrast Color	Meaning/Use	Hazard Severity Panel Illustration
Red	White	Danger hazard severity panels indicate a high level of risk that can result in serious injury or death. The signal word “Danger” is to be limited to the most extreme situation. Danger panels are not to be used for property damage hazards unless personal injury risk appropriate to this level is also involved.	
Orange	Black	Warning hazard severity panels indicate a moderate level of risk that if ignored, could result in death or serious injury. Warning panels should not be used for property damage unless personal injury risk appropriate to this level is also involved.	
Yellow	Black	Caution hazard severity panels indicate a low level of risk that if not avoided, minor or moderate injury could result. Caution panels without the alert symbol may be used to alert against unsafe practices that can result in property damage only.	
Blue	White	Notice severity panels are used to address practices not related to personal injury. The alert symbol is never used with Notice panels. As an alternative to the signal “Notice”, the word “Caution” without the alert symbol may be used to indicate a message not related to personal injury.	



WARNING

Machine Safety: Additional precautionary statements (“**ATTENTION**” and “**IMPORTANT**”) are intended for machine safety and are followed by specific instructions.

ATTENTION: The word “**ATTENTION**” is used to warn the operator of potential machine damage if a certain procedure is not followed.

IMPORTANT: The word “**IMPORTANT**” is used to provide the reader with information necessary to prevent minor machine damage if a certain procedure is not followed.



WARNING: All maintenance and service must be performed by authorized personnel.



WARNING

Disconnect Power Source: Do not connect source power to the flow meter until all installation operations are completed, all covers have been properly installed and all personnel are clear of the equipment.



WARNING

Training: All individuals involved in the installation, operation or maintenance of this equipment must receive and understand training in the safe and proper methods of performing all duties assigned to them at the time of the initial assignment and at least annually thereafter. Safety messages and appropriate response procedures to emergencies or other situations which may arise should be fully understood.



WARNING

Follow Safety Instructions: Carefully read all safety messages in this manual and safety signs on the meter. Keep safety signs in legible condition. Replace any missing or damaged safety signs.

Do not allow anyone to operate the meter without proper instructions.



Keep the meter in proper working condition. Only have the machine serviced by a trained service technician on a routine basis. Unauthorized modifications to the meter may impair the function and/or safety and reduce the life of the meter.



CAUTION

Practice Safe Maintenance: Understand maintenance procedures before doing work. Always disconnect power to the meter before performing any maintenance. Keep all parts in good condition. Remove any buildup of grease, oil, and debris. Ensure that all parts have been properly installed by a certified technician.



WARNING

Proper Source Voltage: Make sure the source power voltage matches the voltage specified on the flow meter name plate.



WARNING

Electrical Connections: Keep all sparks and flames away from battery, as gases given off by electrolyte are explosive. Avoid sparks by connecting the ground cable last and disconnecting it first.

GloTech Corporation

4001 NW 124th Ave • Coral Springs, FL 33065 U.S.A

Phone: (954) 725-8740 • Fax: (954) 725-8741 • www.glo-tech-corp.com

**WARNING**

Inspecting the System Prior to Operation: Always inspect the meter before operation. If the meter appears impaired, do not operate the meter and contact the product support team at 954-908-9955 | gemsupport@glotech-corp.com.

**CAUTION**

Proper Area Lighting: The owner shall provide area lighting as may be required.

**WARNING**

Repairing the Meter: In the event that the GEM flow meter needs to be repaired; disconnect the power source, depressurize the system and contact the support team.

**WARNING**

Lifting Components: Extreme care is needed for lifting components during installation/assembly. Only authorized personnel using the proper lifting equipment may perform this task.

Use caution when lifting heavy objects. Components weighing in excess of 50 lbs. (22.7 kg.) must be lifted with the assistance of another individual or mechanical lifting device.

**WARNING**

Impaired Safety Protection: Do not attempt to operate if protection may be impaired. If the equipment appears to have been changed or operates abnormally, protective devices may be impaired. Do not attempt to operate and have the equipment serviced by authorized personnel.



WARNING: Ensure that power is turned off/disconnected before removing any protective covers.

Do not use this product in a manner not specified in this manual.

**WARNING**

Data Cables: Only use the supplied data cables with this meter. Use of any GloTech non-approved cable may damage the equipment and void warranty.

**WARNING**

Battery Storage and Transport: Lithium batteries are a high energy power source and can become a potential hazard if improperly handled.

GloTech Corporation is not responsible for any battery failures due to operator misuse.

Lithium batteries are non-corrosive. However, extreme heat (contact with open flame or system shorting) will cause the battery to rupture and cause severe injury and damage to equipment.



- When transporting, all packaging must have the proper warning labels clearly displayed on the outside of the containers.
- Do not transport or operate batteries at temperatures beyond their specified range.
- Do not crush, break, or disassemble the battery.
- Do not short circuit, recharge, overcharge, or connect the battery with reversed polarity.
- Do not weld or solder onto the battery casing or within close proximity to the battery.
- Do not submerge the battery in water or apply any fluids onto the battery.
- If the battery is drained of power or damaged, consult GloTech Corporation for replacement.
- Adhere to all local laws and regulations for disposal/recycling of lithium batteries.



CAUTION

Wear Proper PPE: Always wear appropriate (NFPA 70E and OSHA Compliant) Personal Protective Equipment (PPE) for the task being performed. At a MINIMUM, the following are required equipment:

Ear Protection:

Prolonged exposure to loud noise can cause impairment or loss of hearing. Wear a suitable hearing protective device such as earmuffs or earplugs to protect against uncomfortably loud noises. The A-weighted emission sound pressure level at the pivot point does not exceed 70 dB.

Eye Protection:

Sharp Objects, debris and explosions can cause severe eye damage or blindness. Wear Safety Standard approved protection that fully shields the eyes. Additionally, wear a clear plastic face shield that fully surrounds the face from brow to chin and covers the entire width of the face.

Foot Protection:

Prevent foot damage from falling or dropped objects by wearing steel-toe shoes/boots with metatarsal protection.

Head Protection:

Prevent damage from falling or dropped objects on the head by wearing a Class G Hard Hat.

Gloves:

Prevent electrical shock hazards, cuts and burns to the hands by wearing protective rubber gloves-class 0 with leather protector and cloth liner.



CAUTION

Prepare for Emergencies: Be prepared for any emergency that may occur. Keep emergency numbers for doctors, hospital, ambulance service and fire department near your telephone.

GloTech Corporation

4001 NW 124th Ave • Coral Springs, FL 33065 U.S.A

Phone: (954) 725-8740 • Fax: (954) 725-8741 • www.glotech-corp.com



Flow Meter Specifications

Pipe Sizes	2", 3", 4", 6", 8", 10", 12", 14", 16", 18", 20", 24" (bigger sizes available upon request)				
Flange Size	ANSI 150 (DIN and BS available upon request)				
Pressure Rating	290 psi				
Conductivity	≥ 10 μS/cm				
Temperature	Operating	14°F to 131°F (-10°C to 55°C) with a rubber liner -4°F to 212°F (-20°C to 100°C) with a PTFE liner			
	Storage	-40°F to 140°F (-40°C to 60°C)			
Accuracy	±1% of reading between cutoff and 5% of max flow ±0.5% of reading between 5-100% of max flow				
Material	Body	Flow Tube: 304 stainless steel Outer Casing: carbon steel (stainless steel available upon request)			
	Liner	Neoprene rubber liner (PTFE and FEP available upon request)			
	Electronics Housing	Die-cast aluminum with powder-coated exterior			
	Electrodes	316L stainless steel (Titanium, Hastelloy, Tantalum, and others, available upon request)			
	O-rings	EPDM rubber			
Display	Type	36mm x 60mm back-lit dot-matrix LCD			
	Units	Totalizer	Flow Rate		
		Gallons	Cubic Kilometers	GPM	MGD
		Kilo Gallons	1000 Cubic Feet	LPM	MLD
		Liters	Cubic Feet	LPS	BBL/min
		Kilo Liters	Acre-inches	CFM	BBL/day*
		Mega Liters	Acre-feet	CFS	
Cubic Meters	Barrels	CMH			
Power	DC Power	8-32 Vdc			
	AC Power	8-32 Vac			
	Battery	5-pack of Lithium 3.6V 19Ah ('D' size batteries)			
Connectivity	Bluetooth-enabled via "GEM" app (available for iOS and Android)				
Outputs	4-20mA	Calculated between zero flow and meter span			
	Pulse / Frequency	Open collector. Low-power, user-scalable pulse width enabled when battery-powered. Opto-isolated.			
	Modbus	Via RS-485			
Regulatory	UL certified to meet NSF/ANSI/CAN 61 and 372 requirements [Note: 4" and above with Neoprene rubber liner; All sizes with PTFE liners]				
Environmental	NEMA 4x, IP68				

*Contact GloTech for availability of BBL/day



Meter Dimensions

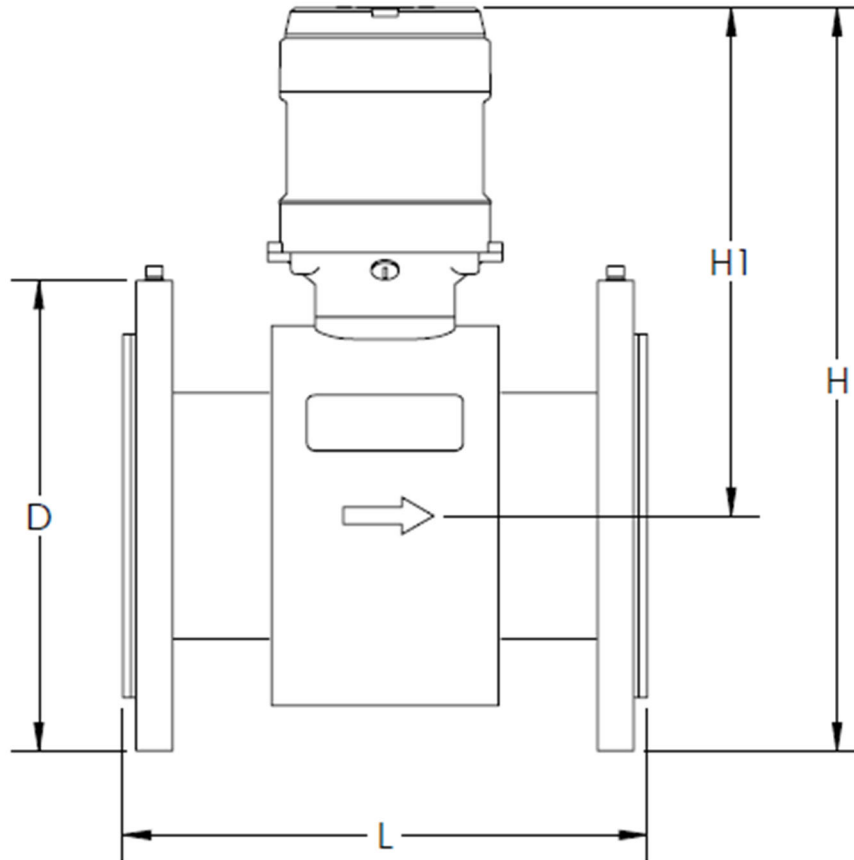

Nominal Dia.*	L	H	H1	D**	Weight in lbs (kg)
2"	7.9 (200.7)	13.0 (330.2)	10.0 (254.0)	6.0 (152.4)	29 (13)
3"	9.1 (231.1)	14.6 (370.8)	10.8 (274.3)	7.5 (190.5)	41 (19)
4"	10.2 (259.1)	15.7 (398.8)	11.2 (284.5)	9.0 (228.6)	51 (23)
6"	12.3 (312.4)	17.4 (442.0)	11.9 (302.3)	11.0 (279.4)	68 (31)
8"	14.3 (363.2)	19.4 (492.8)	12.6 (320.0)	13.5 (342.9)	108 (49)
10"	18.2 (462.3)	21.7 (551.2)	13.7 (348.0)	16.0 (406.4)	157 (71)
12"	20.2 (513.1)	24.1 (612.1)	14.6 (370.8)	19.0 (482.6)	223 (101)
14"	20.2 (513.1)	25.8 (655.3)	15.3 (388.6)	21.0 (533.4)	287 (130)
16"	20.2 (513.1)	28.1 (713.7)	16.3 (414.0)	23.5 (596.9)	342 (155)
18"	24.1 (612.1)	29.8 (756.9)	17.3 (439.4)	25.0 (635.0)	397 (180)
20"	24.1 (612.1)	32.1 (815.3)	18.3 (464.8)	27.5 (698.5)	463 (210)
24"	24.1 (612.1)	35.7 (906.8)	19.7 (500.4)	32.0 (812.8)	573 (260)

* Dimensions are in Inches (mm), larger sizes available upon request

**Standard flange dimensions per ANSI 16.5. Other flange standards (e.g. DIN) are available upon request.

GloTech Corporation

4001 NW 124th Ave • Coral Springs, FL 33065 U.S.A

Phone: (954) 725-8740 • Fax: (954) 725-8741 • www.glo-tech-corp.com

Features

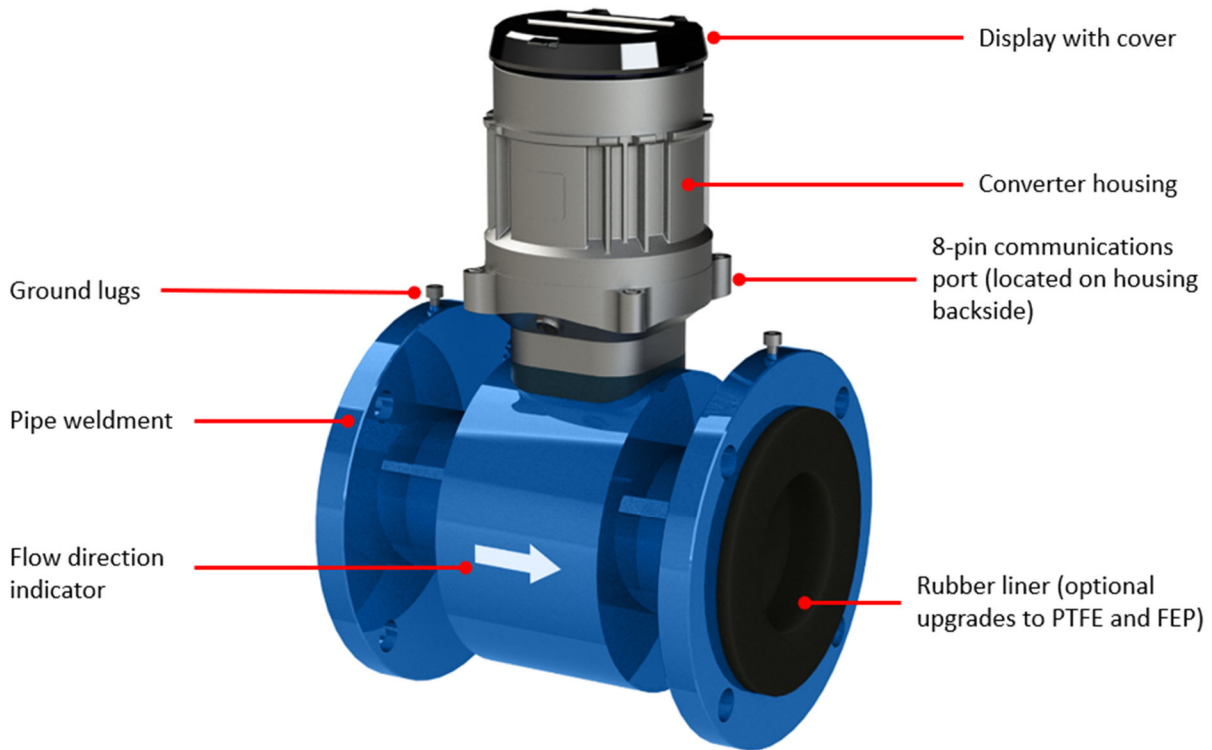

Transportation

During shipping or transporting of the flow meter, avoid exposing the meter to strong shock or vibrations or impact. Avoid scratching the liner inside the pipe.

Storage

If possible, store the meter in its unopened packaging until actual installation. Avoid storing the meter outdoors for an extended period of time. Avoid rain and any direct contact with fluids prior to installation. Avoid exposing the converter housing to direct sunlight.



Installation

Pressure Drop

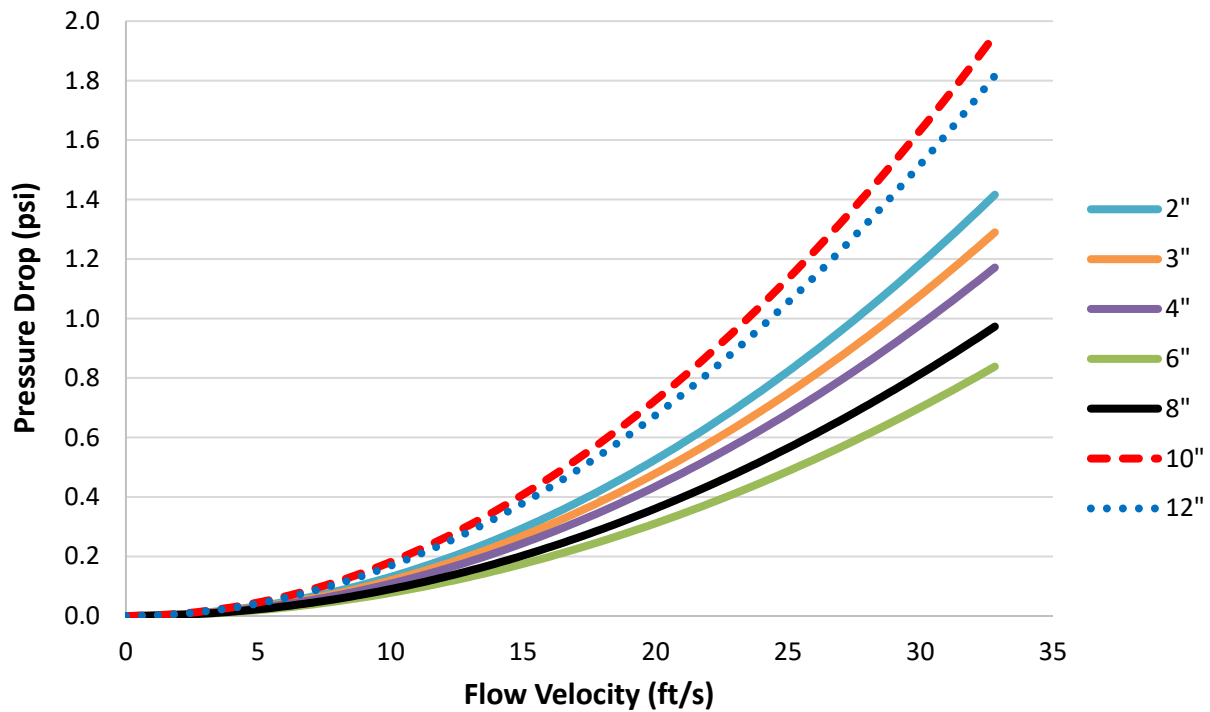

For flow coefficients of larger sizes, please contact us at 954-908-9955 or gemsupport@glotech-corp.com.

Operating Range & Accuracy

Pipe Size	Measurement Range GPM (LPM)			Accuracy	
	Minimum	Maximum	Meter Span	Cutoff to 5% Max Flow	5-100% Max Flow
2"	2.4 (9)	373 (1412)	250 (946)	+/- 1%	+/- 0.5%
3"	6.7 (25)	955 (3615)	600 (2271)	+/- 1%	+/- 0.5%
4"	11 (42)	1492 (5648)	1000 (3785)	+/- 1%	+/- 0.5%
6"	29 (111)	3357 (12709)	2000 (7571)	+/- 1%	+/- 0.5%
8"	47 (177)	5969 (22593)	4000 (15142)	+/- 1%	+/- 0.5%
10"	83 (313)	9326 (35302)	6000 (22712)	+/- 1%	+/- 0.5%
12"	119 (452)	13429 (50835)	8000 (30283)	+/- 1%	+/- 0.5%
14"	213 (807)	18279 (69192)	12000 (45425)	+/- 1%	+/- 0.5%
16"	279 (1054)	23874 (90373)	15000 (56781)	+/- 1%	+/- 0.5%
18"	353 (1337)	30216 (114378)	20000 (75708)	+/- 1%	+/- 0.5%
20"	435 (1647)	37303 (141208)	25000 (94635)	+/- 1%	+/- 0.5%
24"	627 (2372)	53717 (203339)	40000 (151416)	+/- 1%	+/- 0.5%

GEM flow meters are equipped with conductivity-based empty pipe warning functionality.

All GEM flow meters are factory calibrated and require no field calibration.

GloTech Corporation

4001 NW 124th Ave • Coral Springs, FL 33065 U.S.A

Phone: (954) 725-8740 • Fax: (954) 725-8741 • www.glotech-corp.com

Meter Positioning

To ensure accurate flow measurement, great care should be taken to correctly position the GEM flow meter during installation. If meter electrodes are removed from the operating fluid during operation the meter will report a zero reading. Air bubbles and sediment in the pipe can cause inaccurate or false readings.

It is preferred that the flow meter be installed in a pipeline location where the pipe will be full when there is flow. Orientate the flow meter in a vertical position (meter positioned on top of the pipe) as well. Never install the flow meter with the meter horizontal to the pipeline or below the pipe. The following diagram shows proper and improper meter positioning.

Incorrect Meter Positioning

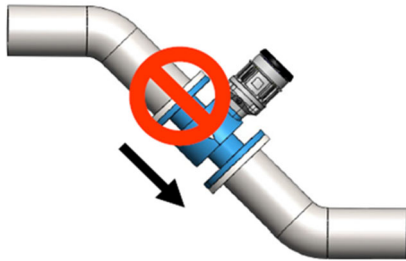

Air can be trapped.
Loss of accuracy.

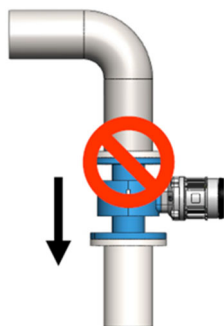

Vertical downflow.
Open discharge.



Clock meter up to 45° **if necessary**

Correct Meter Positioning

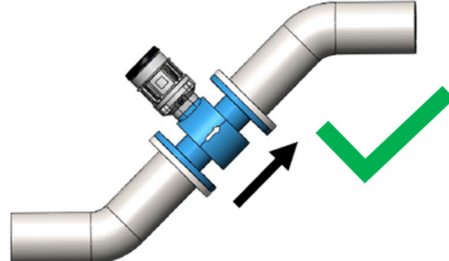

Air can bleed off.
Higher accuracy.

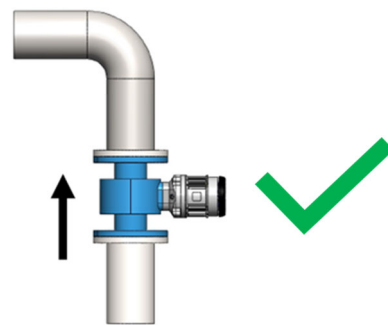

Vertical upflow.
With full pipe.

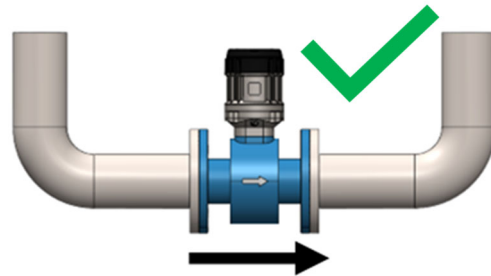

U-pipe configuration ensures full pipe.

Straight Pipe Recommendations

To achieve optimal meter accuracy and performance, it is necessary to provide sufficient lengths of straight pipe upstream and downstream from the GEM flow meter. Below are common examples of installation conditions and recommended minimum straight pipe lengths. These serve as general guidelines and do not cover all possible conditions or any specific local regulatory requirements. If there is a question with regards to a specific configuration, please contact the manufacturer for further support.

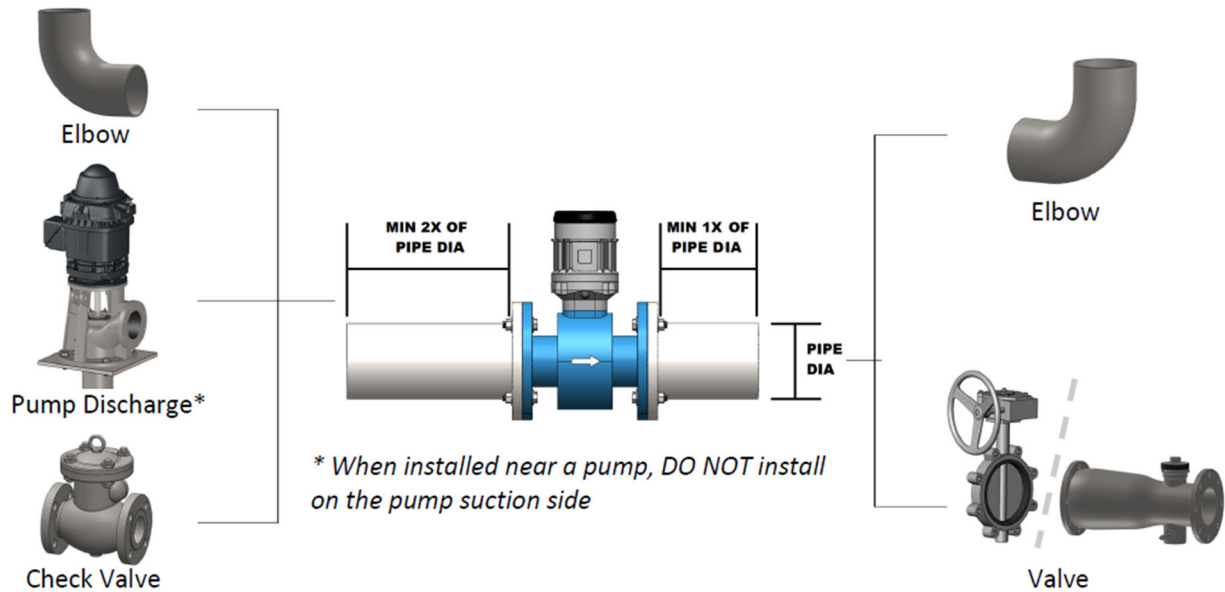

OTE: Valve denotes a fully open butterfly or gate valve. When installed with a pump, the GEM should always be located downstream of the pump discharge. Installing meters upstream of a pump intake is generally not recommended.

Close Coupled to Turbine Pump Elbow

It is widely recognized that often, the most convenient and preferred installation method for the flow meter is to install it directly to a turbine or centrifugal pump discharge. GloTech has conducted laboratory testing to show the GEM can provide accuracy of up to +/- 2% when close coupled to a pump elbow of a vertical well pump.

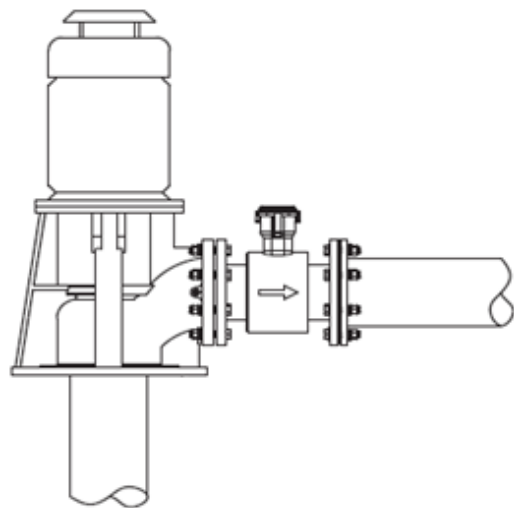

GloTech Corporation

4001 NW 124th Ave • Coral Springs, FL 33065 U.S.A

Phone: (954) 725-8740 • Fax: (954) 725-8741 • www.glotech-corp.com

Grounding



WARNING: Electrical Shock

When installing GEM flow meters to a plastic pipeline, or when externally powered, it is very important to ground the meter to avoid electrical shock hazard. Failure to do so can result in electrocution.

IMPORTANT! Use Proper Grounding

Properly ground the flow meter per the following grounding instructions. Proper grounding will protect signal from the meter against stray electrical noise and/or surges. Proper grounding ensures the noise is carried through the sensor body and a noise-free measuring area within the sensor body. It is highly recommended to ground both flanges of the meter for optimal results.

When grounding on metal pipe, the electric potential of the fluid, meter and surrounding pipe must be equalized. This is done by connecting the ground wires on the flow meter body to one of the lug locations on the mating flange connection.

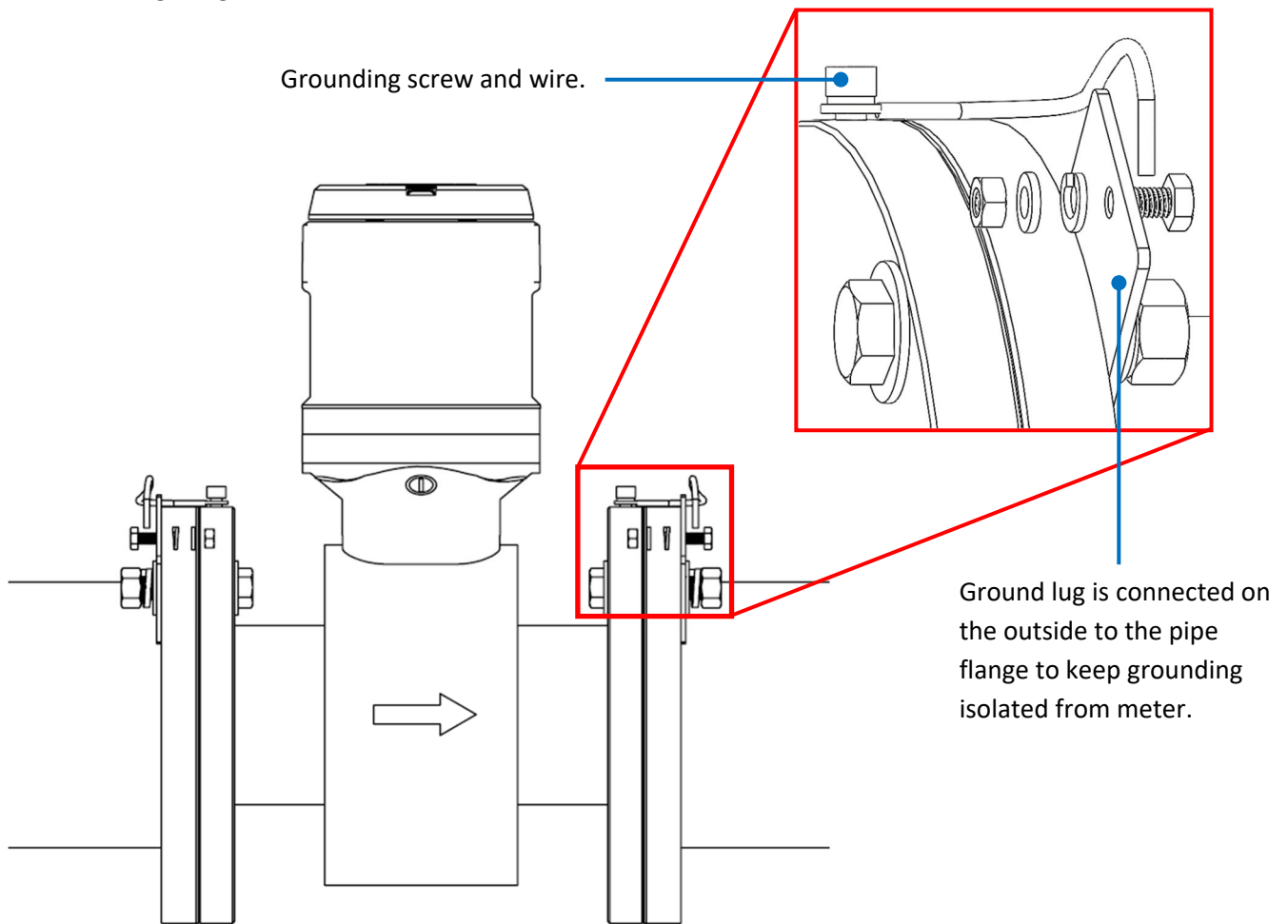

NOTE: Make sure the ground wire or lug is between the flange bolt head (or nut) and the outside surface of the mating pipe flange. This grounding must be completely isolated from the flow meter.



For plastic pipe installations, a grounding rod or other ground-to-earth connection must be installed. The diagram below is shown for illustration purposes only. Exact dimensions of grounding rod may need to be adjusted on a case-by-case basis for optimal results.

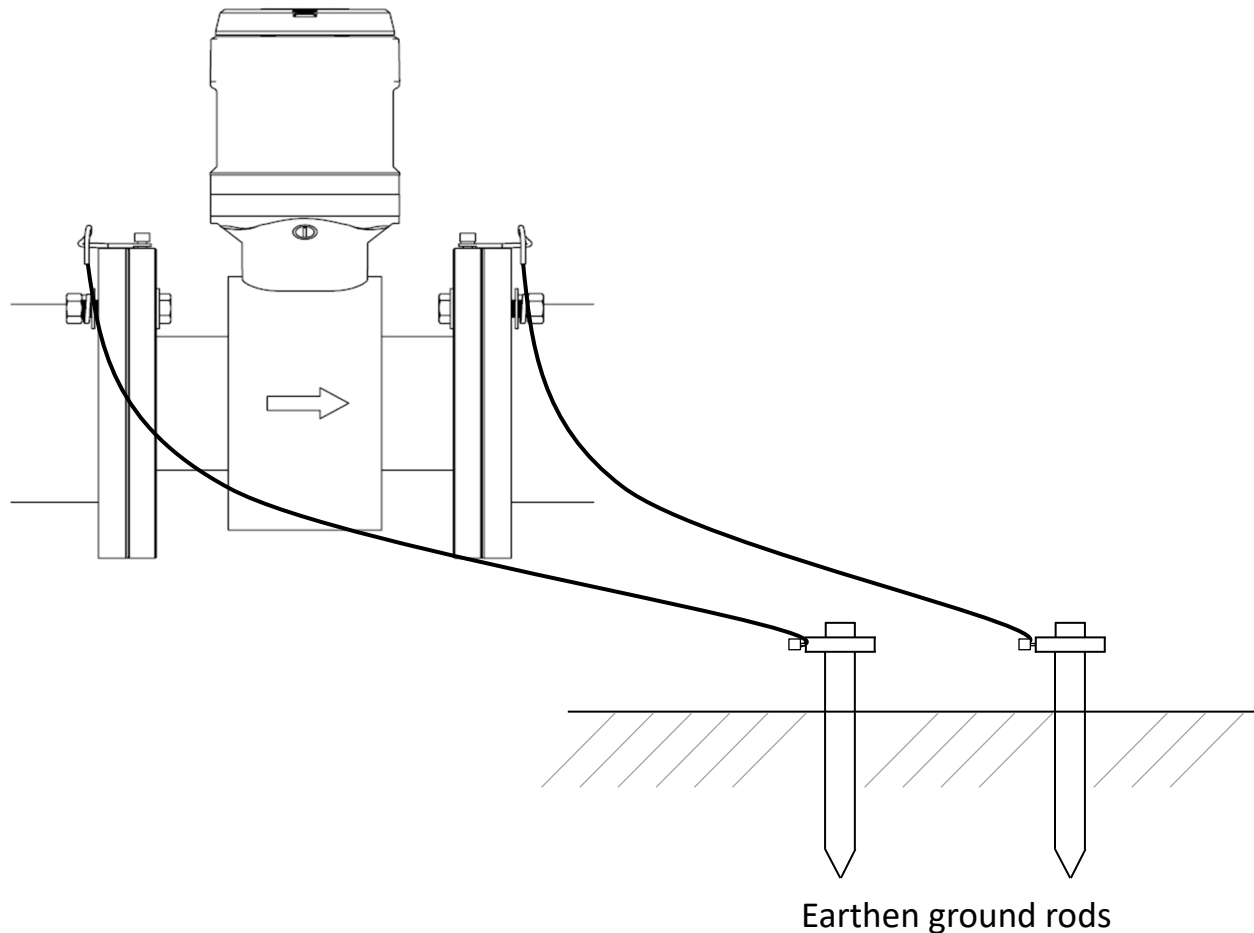

Chemical Injection Applications

In chemigation applications, the GEM flow meter must be placed either upstream from the chemical injection line or a substantial distance downstream (at least ~50 OD) in a manner that complete mixing of water and chemical occurs before the solution reaches the flow meter. Proper placement will prevent spikes and drops in readings that can result from fluids with varying conductivity pass through the meter.

Drinking Water Applications

All 2" - 80" GEM meters with optional PTFE liners are UL certified to meet the requirements of NSF/ANSI/CAN 61. Standard neoprene liners are certified on 4" and above.

GloTech Corporation

4001 NW 124th Ave • Coral Springs, FL 33065 U.S.A

Phone: (954) 725-8740 • Fax: (954) 725-8741 • www.glo-tech-corp.com

Wiring GEM Power / Output Cable

IMPORTANT! External Power Source Needed for Analog/Digital Output

- External power is required for proportional and reliable signal output to the main control panel. Never attempt to only wire the analog/digital output without using external power source.

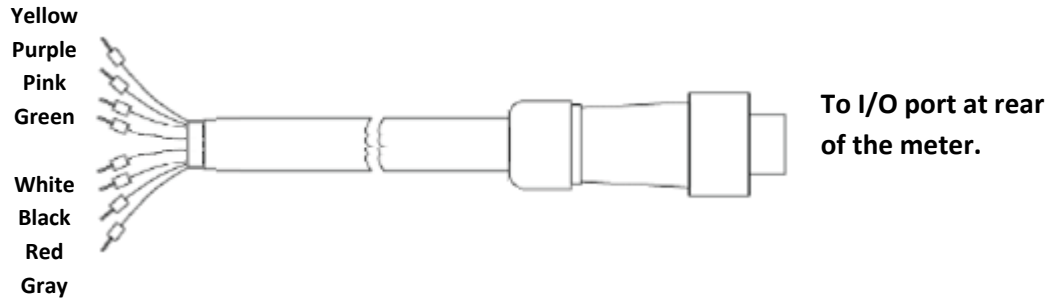

WIRE COLOR	FUNCTION
Yellow	Power (+)
Purple	Power (-)
Pink	485A (+)
Green	485B (-)
White	Digital Pulse (+)
Black	Digital Pulse (-)
Red	Analog 4-20mA (+)
Gray	Analog 4-20mA (-)

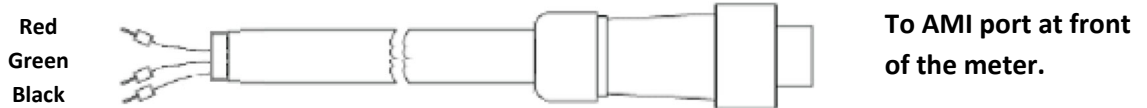

WIRE COLOR	FUNCTION
Red	Clock / Power
Green	Data
Black	Common



GEM Stub Cable

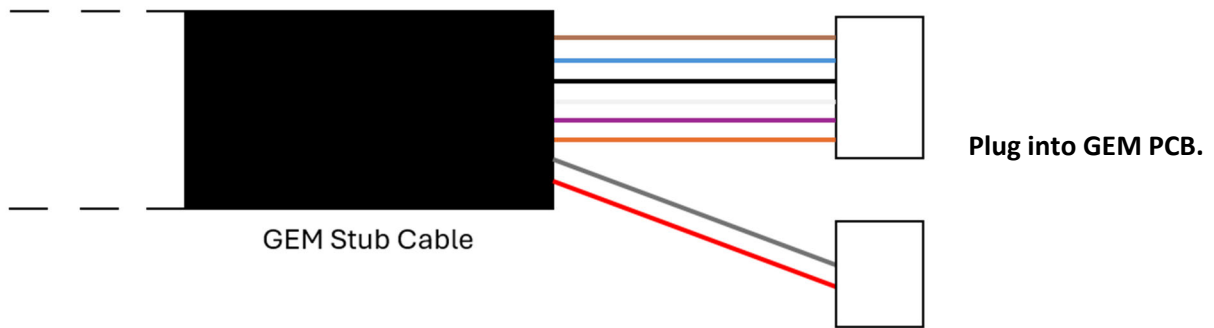

WIRE COLOR	FUNCTION
Brown	485A (+)
Blue	485B (-)
Black	Digital Pulse (-)
White	Digital Pulse (+)
Purple	Power (-)
Orange	Power (+)
Gray	Analog 4-20mA (-)
Red	Analog 4-20mA (+)

GloTech Corporation

4001 NW 124th Ave • Coral Springs, FL 33065 U.S.A

Phone: (954) 725-8740 • Fax: (954) 725-8741 • www.glotech-corp.com

Wiring Configurations

Analog (4-20mA)*

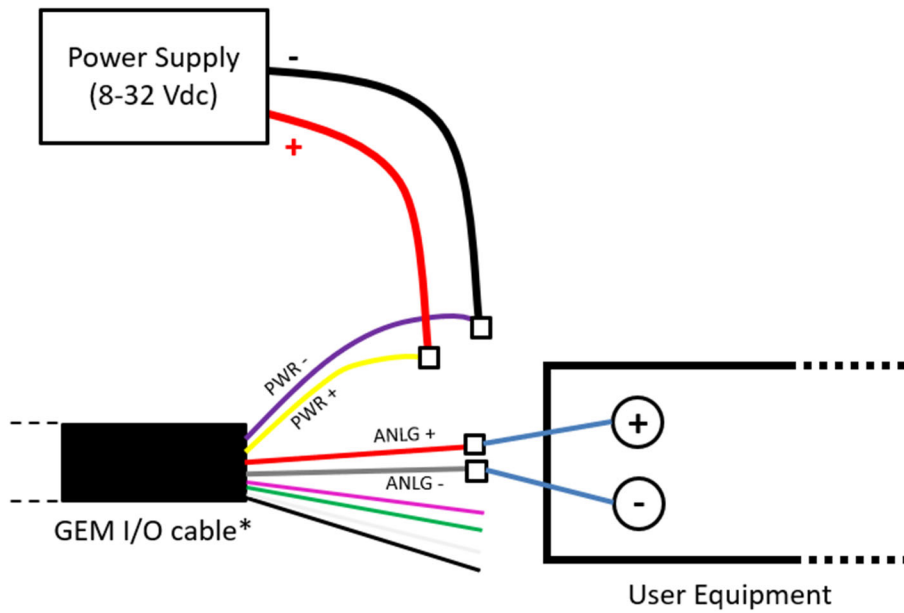

Digital (Pulse / frequency output)

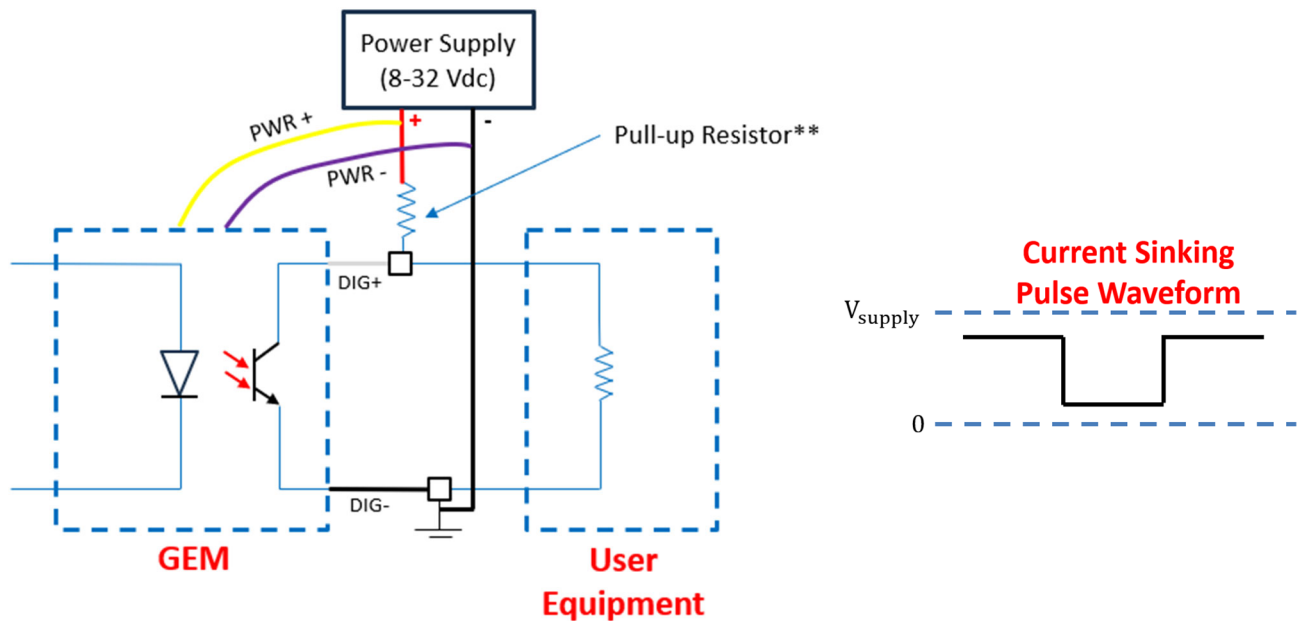

*Color convention consistent with [IOM](#).

**This drawing is for reference purposes only. Pull-up resistors might not be needed for some devices.



Commonly Used Telemetry/Display Devices

Wiring Terminals (Digital Output)

WIRE	AMI VAPOR XI	DWYER RTI2	DWYER PPM	SENTRALINK LT	DM700
YELLOW	POWER IN (+)	POWER (+)	P+	24V	POWER 6-24
WHITE	DIGITAL IN (+)	SENSOR (+)	S+	COM	GROUND
BLACK	DIGITAL IN (G)	SENSOR (-)	COM	COM	PULSE 6
PURPLE	POWER IN (-)	POWER (-)	P-	CH1	GND
RESISTOR	NO	YES	NO	NO	NO

K Factor Settings

METER SIZE	AMI VAPOR XI	DWYER RTI2 / PPM	SENTRALINK LT	DM700
2"	1.25	48	48	48
3"	3	20	20	20
4"	5	12	12	12
6"	10	6	6	6
8"	20	3	3	3
10"	30	2	2	2
12"	40	1.5	1.5	1.5
14"	60	1	1	1
16"	75	0.8	0.8	0.8
18"	100	0.6	0.6	0.6
20"	125	0.48	0.48	0.48
24"	200	0.3	0.3	0.3

Modbus Registers

The GEM series mag meter supports Modbus communication protocol that allows for the monitoring and configuration of basic meter parameters such as flow readings, units, alarms, etc.

Notes: Modbus communication is designed for use when meter is externally powered. Running it on battery may significantly reduce the expected battery life.

1. The GEM meter supports Modbus via an RS485 serial port. It supports a baud rates from 600 to 19,200 bps, with a default of 9,600 bps. It contains 8 data bits, one or two stop bit(s), and a parity bit (none, even, odd):

GloTech Corporation

4001 NW 124th Ave • Coral Springs, FL 33065 U.S.A

Phone: (954) 725-8740 • Fax: (954) 725-8741 • www.glo-tech-corp.com

Baud Rate	Data Bit	Stop Bit	Parity Bit
2,400	8	1	Even
4,800		2	
9,600*			Odd
14,400			
19,200			

* Default baud rate

- The data frame / Application Data Unit (ADU) consists of address code (1 byte), function code (1 byte), data section (n byte), and CRC (Cyclic Redundancy Check) code (2 byte).
- The flow totalizer uses a 4-byte integer (hexadecimal). The instantaneous flow rate uses a 4-byte floating point number that follows the IEEE754 standard format (hexadecimal).
- A function code of "03" is used to read meter (i.e. SLAVE) parameters. For example:

MASTER Broadcasts:		SLAVE Responses	
01	Address (SLAVE ID)	01	Address (SLAVE ID)
03	Function Code (Read data)	03	Function Code (Read data)
00	Register Address High	04	Number of Bytes (4)
00	Register Address Low	80	First Data in 1st register
00	Register Quantity High	04	Second Data in 1st register
02	Register Quantity Low	80	First Data in 2nd register
CRCL	CRC Low	80	Second Data in 2nd register
CRCH	CRC High	CRCL	CRC Low
		CRCH	CRC High

- Meter address (SLAVE ID) can be configured in the GEM Android app via Bluetooth. Each meter should be configured with a unique address between 1-255 (excluding 43, 64, 84, 97, 116 which are reserved).
- Data map*:

Address		Description	Data Type	Data Length (Byte)
HEX	DEC			
00	00	Instantaneous Flow	FLOAT**	4
02	02	Instantaneous Flow Unit	SHORT	2
03	03	FWD Totalizer Integer	LONG	4
05	05	FWD Totalizer Decimal	FLOAT	4
07	07	FWD Totalizer Unit	SHORT	2
08	08	REV Totalizer Integer	LONG	4
A	10	REV Totalizer Decimal	FLOAT	4
C	12	REV Totalizer Unit	SHORT	2
E	14	Empty Pipe Alarm	SHORT	2
18	24	Meter Size	FLOAT	4

* Contact GloTech for access to additional meter parameters

** FLOAT represents floating point number that follows the IEEE754 standard format

- Flow unit encoding:

Instantaneous Flow Rate Unit



Address		Description	Data Type	Data Length (Byte)	Access
HEX	DEC				
02	02	Instantaneous Flow Unit	SHORT	2	Read/Write

00: LPS 01: LPM 02: GPS 03: GPM 04: CFS 05: CFM 06: CMM
07: CMH 08: MGD 09: MLD 10: MI 11: BBL/min

Totalized Flow Unit

Address		Description	Data Type	Data Length (Byte)	Access
HEX	DEC				
07	07	FWD Totalizer Unit	SHORT	2	Read/Write
0C	12	REV Totalizer Unit	SHORT	2	Read/Write

00: L 01: KL 02: ML 03: GAL 04: KGAL 05: MGAL 06: CM 07: KCM 08: MCM
09: AF 10: KAF 11: MAF 12: CF 13: KCF 14: MCF 15: AI 16: KAI 17: MAI
18: MID 19: K-MID 20: M-MID 21: BBL

Programming Examples

1. Instantaneous Flow (FLOAT)

Master broadcasts:

01H	03H	00H	00H	00H	02H	C4H	0BH
-----	-----	-----	-----	-----	-----	-----	-----

Slave responses:

01H	03H	04H	D0	D1	D2	D3	CRC16L	CRC16H
-----	-----	-----	----	----	----	----	--------	--------

2. Instantaneous Flow Unit (SHORT)

Master broadcasts:

01H	03H	00H	02H	00H	01H	25H	CAH
-----	-----	-----	-----	-----	-----	-----	-----

Slave responses:

01H	03H	02H	00	D0	CRC16L	CRC16H
-----	-----	-----	----	----	--------	--------

3. Forward Totalizer Integer (LONG)

Master broadcasts:

01H	03H	00H	03H	00H	02H	34H	0BH
-----	-----	-----	-----	-----	-----	-----	-----

Slave responses:

01H	03H	04H	D0	D1	D2	D3	CRC16L	CRC16H
-----	-----	-----	----	----	----	----	--------	--------

4. Forward Totalizer Decimal (FLOAT)

Master broadcasts:

01H	03H	00H	05H	00H	02H	D4H	0AH
-----	-----	-----	-----	-----	-----	-----	-----

Slave responses:

01H	03H	04H	D0	D1	D2	D3	CRC16L	CRC16H
-----	-----	-----	----	----	----	----	--------	--------

5. Forward Totalizer Unit (SHORT)

Master broadcasts:

01H	03H	00H	07H	00H	01H	35H	CBH
-----	-----	-----	-----	-----	-----	-----	-----

Slave responses:

01H	03H	02H	00	D0	CRC16L	CRC16H
-----	-----	-----	----	----	--------	--------

6. Reverse Totalizer Integer (LONG)

Master broadcasts:

01H	03H	00H	08H	00H	02H	45H	C9H
-----	-----	-----	-----	-----	-----	-----	-----

Slave responses:

01H	03H	04H	D0	D1	D2	D3	CRC16L	CRC16H
-----	-----	-----	----	----	----	----	--------	--------

7. Reverse Totalizer Decimal (FLOAT)

Master broadcasts:

01H	03H	00H	0AH	00H	02H	E4H	09H
-----	-----	-----	-----	-----	-----	-----	-----

Slave responses:

01H	03H	04H	D0	D1	D2	D3	CRC16L	CRC16H
-----	-----	-----	----	----	----	----	--------	--------

8. Reverse Totalizer Unit (SHORT)

Master broadcasts:

01H	03H	00H	0CH	00H	01H	44H	09H
-----	-----	-----	-----	-----	-----	-----	-----

Slave responses:

01H	03H	02H	00	D0	CRC16L	CRC16H
-----	-----	-----	----	----	--------	--------

9. Empty Pipe Alarm (SHORT)

Master broadcasts:



01H	03H	00H	0FH	00H	01H	B4H	09H
-----	-----	-----	-----	-----	-----	-----	-----

Slave responses:

01H	03H	02H	00	T/F	CRC16L	CRC16H
-----	-----	-----	----	-----	--------	--------

10. Meter Size* (FLOAT)

Master broadcasts:

01H	03H	00H	18H	00H	02H	44H	0CH
-----	-----	-----	-----	-----	-----	-----	-----

Slave responses:

01H	03H	04H	D0	D1	D2	D3	CRC16L	CRC16H
-----	-----	-----	----	----	----	----	--------	--------

*Meter size unit in millimeters (mm)

Data Conversion Examples

Convert D0, D1, D2, D3 data from hex to integers or floats. For example: A value of 1600 can be expressed as follows:

- 0x44,0xc8,0x00,0x00 - FLOAT
- 0x00,0x00,0x06,0x40 - LONG
- 0x06,0x40 - SHORT

*Consult GloTech Corporation for wiring instruction to additional devices

Operations

Vibrations

Vibrations in the system pipeline can damage the flow meter and should be negated. The meter meets IEC 68-2-64 standards for shock resistance. However, if there is significant vibration in the pipeline, support brackets can be installed on both sides of the meter to help eliminate vibration.

Power Supply

The GEM flow meter can be powered externally or by battery power. An external power source that provides 8 to 32 V DC/AC. When installed, the battery pack can be used as a backup power source. A battery pack consisted of 5 lithium 3.6V 19Ah “D” sized batteries with an estimated 3 to 5 years of life.

An indicator on the meter will show a battery symbol with bars representing the power level of the batteries. When the battery power is depleted, the battery symbol will show no power level bars (empty).

Bluetooth App

A Bluetooth application for Android/iOS is available to adjust meter parameters. The iOS phone app is available for download on the App Store by searching for “GloTech” or “GEMconfig”. The android app can be downloaded using the information below:

Android

- Download Link: <https://glotech-corp.com/gem-android-app/>
- Password for Download: *GEM*

iOS

- Download Link: <https://apps.apple.com/us/app/gemconfig/id1558967205>

Phone Installation Instructions

1. Download the GEM app from the provided link.
2. Install the app on the phone; the phone may need to be set to authorize application installation from unknown sources.
 - a. **Android devices:** Make sure that under “settings” ->“Location”, that “Use location” is enabled. The individual permission for the app may also need to be adjusted.
3. On app start up, the password **2988** must be entered when prompted.
4. Make sure your Bluetooth on the Android device is enabled; while standing close to the meter you will see the serial number appear on the menu. Select the meter number to open the parameters.
5. You can now adjust any of the parameters by selecting it on the menu. The app will display a message to confirm when the parameter has been successfully updated.

User Interface

The GEM uses a low power consumption dot matrix LCD rate/ total display. The screen displays two lines of information. The top line shows the total flow accumulation. The bottom line displays the flow rate.

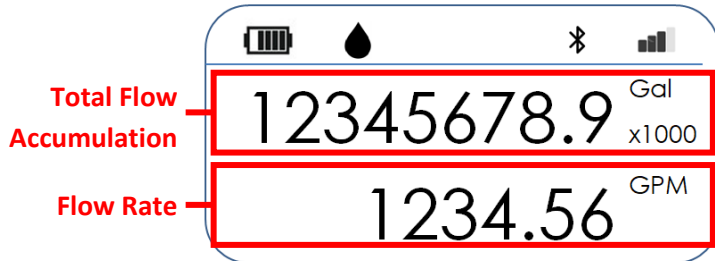

The meter provides the following three power status displays. The screen will be blank if there is no power to the meter.



If there is an external power source, a power plug symbol will display.

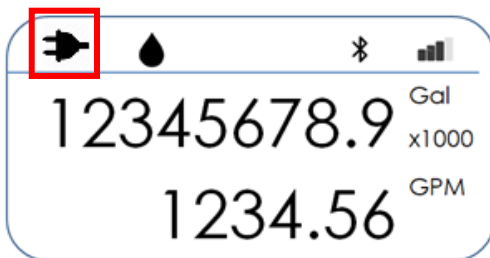

For battery power, a little battery icon displays in the top-left corner of the screen.

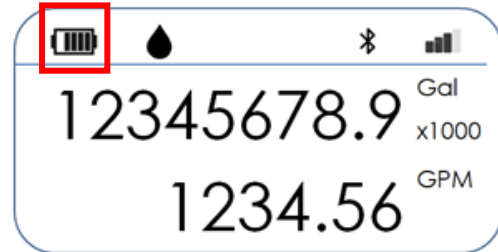

The meter continuously monitors battery life. When the battery power is low, the battery cell icon will show an empty battery. Battery replacement is required at this time.

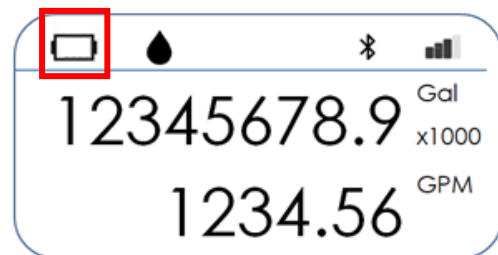

When the meter detects an empty pipe, the meter will stop measuring and display an empty droplet symbol.

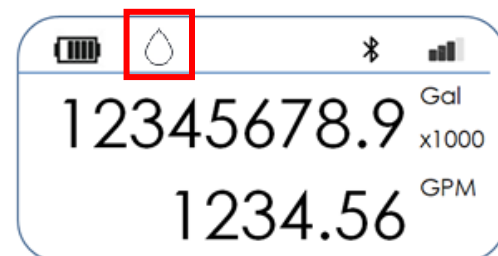

If direction of flow of the medium is reversed, the meter will display the “-” indicator.



When the data logger is enabled, a sheet of paper with the word “LOG” will appear in the upper right-hand corner.

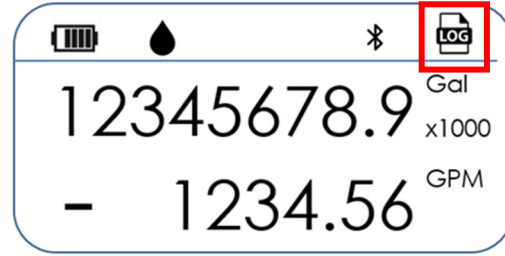

When the job totalizer is enabled, the totalizer will switch between displaying the totalizer 5 seconds and the job totalizer for 10 seconds.

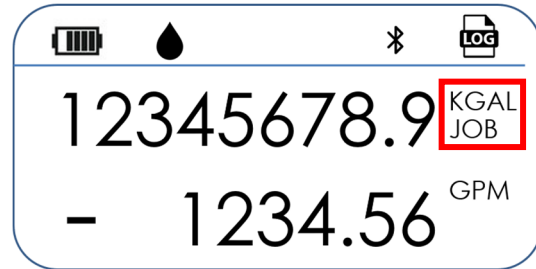

Available Display Units

Totalizer	Flow Rate
L, Lx1000, ML, GAL, GALX1000, MGAL, CM, CMx1000, MCM, AF, AFx1000, MAF, CF, CFx1000, MCF, AI, AIX1000, MAI, MID, MIDx1000, MMID, BBL	LPS, LPM, GPS, GPM, CFS, CFM, CMM, CMH, MGD, MLD, MI, BBL/min



LCD Unit Display Formats

22 flow totalizer unit options selectable via GEM Config

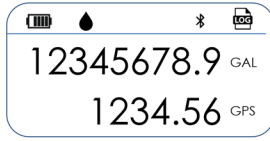

Gallon



Gallon x 1000

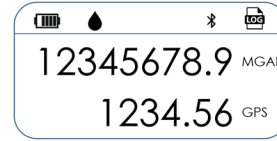

Mega Gallon

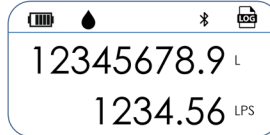

Liter

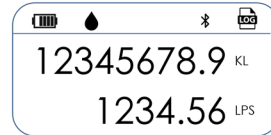

Liter x 1000

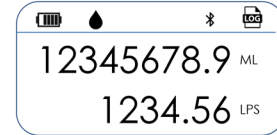

Mega Liter

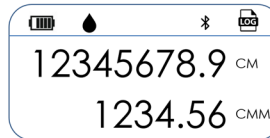

Cubic Meter

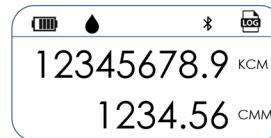

Cubic Meter x 1000

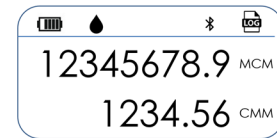

Mega Cubic Meter

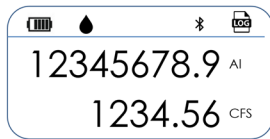

Acre Inch



Acre Inch x 1000

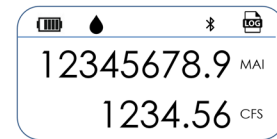

Mega Acre Inch

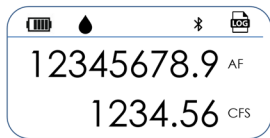

Acre Feet



Acre Feet x 1000

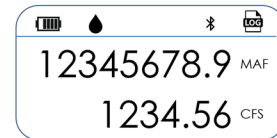

Mega Acre Feet

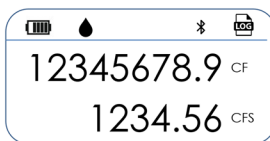

Cubic Feet

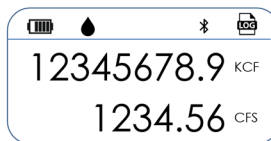

Cubic Feet x 1000

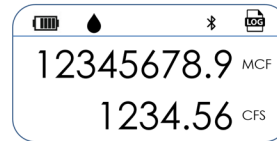

Mega Cubic Feet

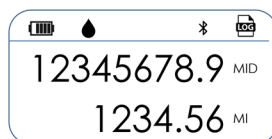

Miner's Inch Day

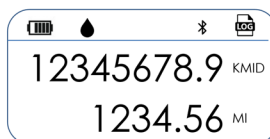

Miner's Inch Day x 1000

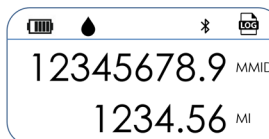

Mega Miner's Inch Day

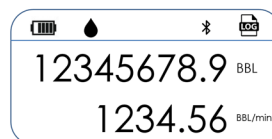

Barrel

GloTech Corporation

4001 NW 124th Ave • Coral Springs, FL 33065 U.S.A

Phone: (954) 725-8740 • Fax: (954) 725-8741 • www.glotech-corp.com

13 flow totalizer unit options selectable via GEM Config



Gallons / Second



Gallons / Minute

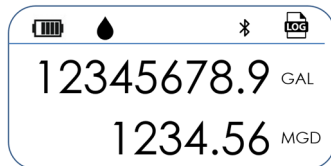

Mega Gallons / Day

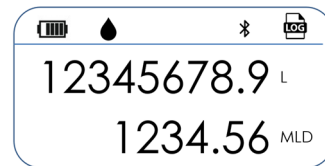

Mega Liters / Day

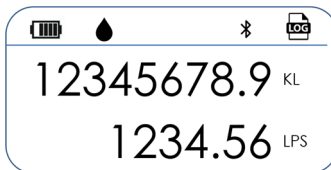

Liters / Second

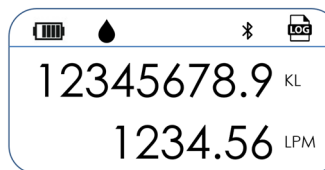

Liters / Minute

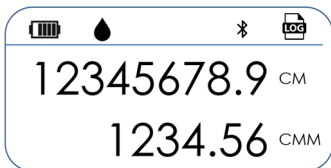

Cubic Meter / Minute

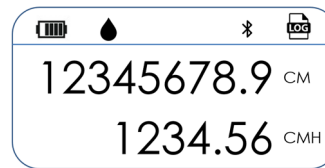

Cubic Meter / Hour

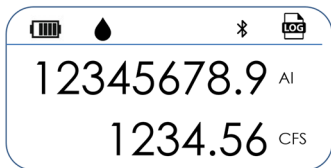

Cubic Feet / Second

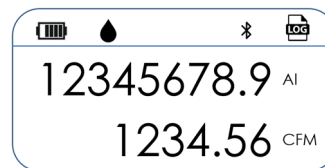

Cubic Feet / Minute

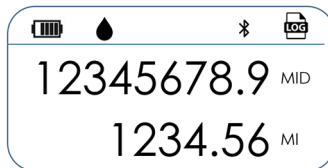

Miner's Inch



Barrels / min

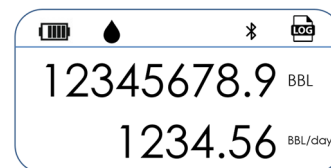

Barrels / Day

Troubleshooting Guide

PCB & Battery Replacement



IMPORTANT!

Upon every battery pack replacement, replace the desiccant pack with a fresh pack included in the battery kit.

Tools needed:

- 1 x 4mm Allen wrench.
- 1 x 3mm Philips screwdriver.

Step-by-step instructions:

1. Use the 4mm Allen wrench to loosen the four (4) 5mm hex head cap screws on the meter housing cover. The photo shows two screws. The remaining two screws are located on the opposite side of the housing. **These screws are captive and should not be removed from the cover.** Once the screws are loosened, the housing cover can be pulled up and removed from the meter.



2. Remove the display cover by unlatching the three (3) clips that hold it to the battery cover. Two clips are shown, and the last clip is located on the opposite side.

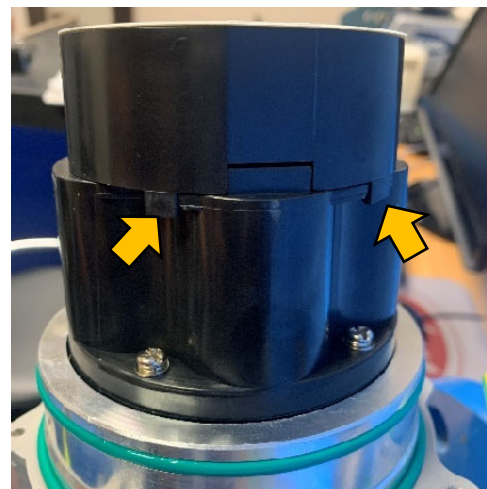

3. Once the display cover is removed, the LCD can be unplugged and unlatched from the battery cover.

NOTE: If the purpose of disassembly is battery replacement, the LCD **ONLY** needs to be unplugged.

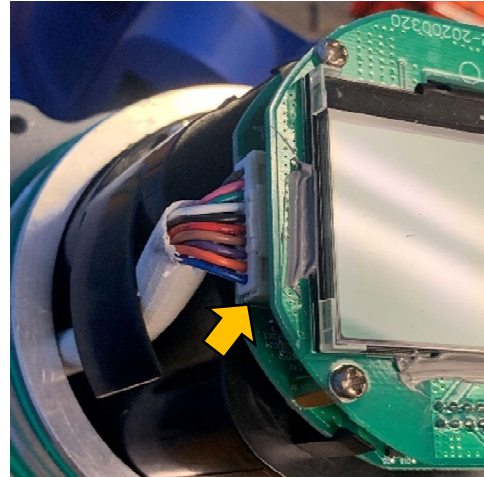

4. Use the 3mm Phillips screwdriver to remove the three (3) Phillips screws securing the battery cover to the meter. One screw is shown in the picture, the other two are on the opposite side.

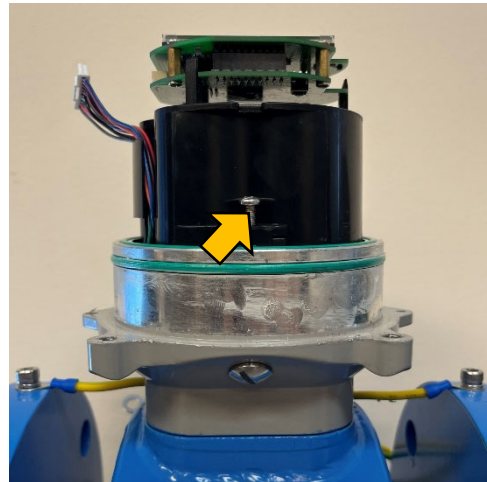

5. Remove the battery cover and carefully lift the battery. Once PCB is exposed, unplug the battery from the PCB. Next, the stub cable can be disconnected from the PCB.

NOTE #1 (GEM2 ONLY): The AMI cable (located next to the battery cable) will **NEED** to be unplugged if the PCB is being replaced.

NOTE #2: If the purpose of disassembly is battery replacement, the stub cable does **NOT** need to be unplugged. Skip to step 8.

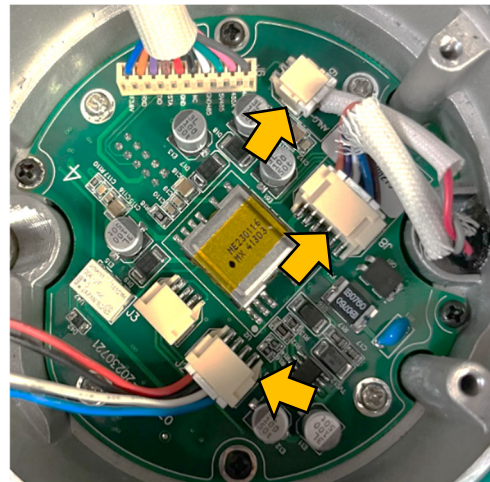

6. Remove the four (4) screws securing the PCB to the meter. In some cases, these screws may be a different color. Ensure that the four screws being removed are outside the white line traced around the PCB board.

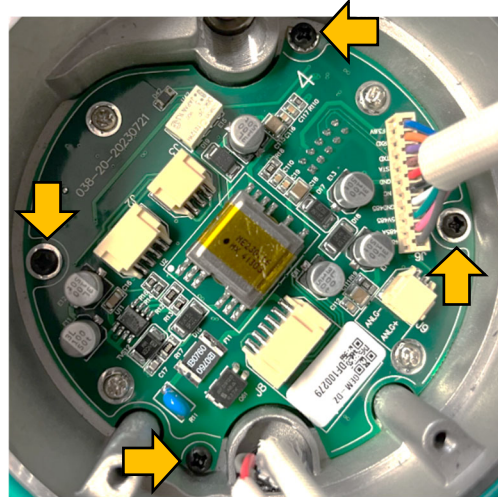

7. Carefully lift the PCB up and unplug the signal wires and the excitation wires.

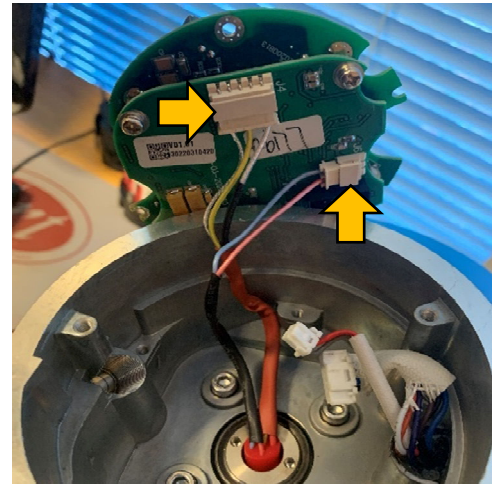

8. Put everything back together and make sure that there are no loose cables. This is especially important when putting the lid back on as cables can get crushed. The four bolts securing the meter head to the electronics housing should be tightened as follows:

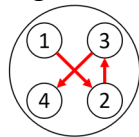



Any other tightening sequence may compromise the O-ring seal necessary to keep water from entering the electronics housing.



NOTE: ALL cable connectors are designed such that they will **only** fit with their designated socket on the PCB. NEVER force a connection that does not fit.

Troubleshooting Summary

Problem	Possible Cause	Diagnostic Steps	Solution
No display	Dead battery	Check battery voltage. A good battery will give a reading of $\geq 3.5V$	Replace battery pack. Refer to “PCB & Battery Replacement”
	Screen timeout to conserve battery life	-	Close and reopen lid
	Electronics Failure	Check battery voltage is $\geq 3.5V$ and there is no visible damage to the wiring harnesses	Replace display PCB. Refer to “PCB & Battery Replacement”
Flow rate reads zero when there is flow	Flow is below cutoff	Ensure system flow rate is higher than the flow cutoff of the meter	Reading will resume when flow increases. Refer to pg. 10
	There is air in the meter	-	Move meter to a location where pipe is full under any system condition
	Valve is closed	-	Open valve to allow flow
Flow rate “flickers” when there is flow	There is air in the meter	-	Move meter to a location where pipe is full under any system condition. Refer to pg. 11
Jumpy readings	Improperly grounded	-	Check for proper grounding. Refer to pg. 16
	Turbulent/Pulsing flow	-	Use external power source (allows more flow averaging)
	Rapidly changing conductivity (for chemigation applications)	-	Install meter upstream of the chemigation entry location (or far enough downstream for thorough fluid mixing ~50-100 OD).
Leakage between flange and pipe	Gasket is missing	-	Add gasket between flange and pipe
Meter does not show up on Bluetooth app	Bluetooth module is temporarily malfunctioning	-	Hard reset meter by unplugging battery. Refer to “PCB & Battery Replacement” for steps on how to unplug battery
Meter is erroneously registering flow or accumulating totalizer	Air or moisture in the line; Flexible hose is not filled when pump is off	-	Move meter to a location where pipe is full under any system condition; Install meter with skid and rigid piping. Install air bleeding valves and inverse U pipes to keep air away from meter
	Dirty electrodes	-	Carefully clean electrodes. Refer to additional Troubleshooting Guide .
Empty Pipe error 	Pipe is not full, or fluid level is fluctuating	-	Move meter to a location where pipe is full under any system condition
Excitation error 	Open/short circuit or electronics malfunction	-	Refer to “Excitation Error Guide”
		-	Replace PCB. Refer to “PCB & Battery Replacement”
No output to telemetry device or reading does not match meter	Incorrect K-factor.	Check that K-factor matches manual (value and units).	Set proper k-factor and k-factor units
	Missing pull-up resistor	-	Add (usually 3k-10k Ω) resistor between pulse + and power +
	Incorrect wiring	-	Check wiring
	Error on receiving device	-	Verify meter output using multimeter.
	Incorrect power supply	-	Use compatible power supply with meter

For additional support, please call our GEM support line at: 954-908-9955.



Accessories and Spare Parts

Item	Description
GEMRD	GEM Remote Display Kit
GEMC15F	15 ft power/output cable
GEMC25F	25 ft power/output cable
GEMC50F	50 ft power/output cable
GEMC100F	100 ft power/output cable
GEMBT	Spare / replacement battery kit
GEMPB	PCB replacement kit
GEMUC	Lid repair kit
GEMDP	Stub cable

Revision Table

Rev	Date	By	Description
-	06.30.2019	-	Product Launch
A	07.13.2020	DS	Applies to meter design version 0.1 with 4-20mA output
B	07.24.2020	DS	Applies to meter design version 0.2 with flanged electronic housing
C	06.08.2021	DS	Bluetooth App Instructions, NSF/ANSI/CAN 61 Certification Addition
D	03.09.2023	AD	Troubleshooting section; updated table of contents, battery replacement section, minimum flow rate for each meter size
E	07.28.2023	AD	General updates for GEM2 launch
F	06.21.2024	EE	General updates
G	03.19.2025	MG	Warranty statement added, template updated, other general updates



Appendix - Limited Warranty Statement

Effective Date:	February 6, 2025
Products Covered:	Magnetic flow meters sold by GloTech Corporation manufactured on or after February 7, 2023

Magnetic flow meters (“meters”; “product”) manufactured by GloTech Corporation (“GloTech”), when delivered in new condition inside original packaging, are warranted to the original purchaser to be free from defects in materials and workmanship. **Meters properly installed and operated shall be warranted for a period of two (2) years from the date of installation, with proof of install date, and/or warranty registration. Otherwise, the warranty period shall be two (2) years from the date of product shipment from GloTech.**

Warranty Terms and Conditions:

- I. Purchaser must notify GloTech of potential product defect(s) in a timely manner and provide the required documentation or proofs GloTech will require to honor warranty of the suspected defect(s).
 - a. Purchaser must notify GloTech in writing and provide: name and address, a description of the product involved, proof of installation or warranty registration, and the nature of the defect.
- II. Based on the documentation received, GloTech may request to inspect the product to confirm the defect/failure.
 - a. In the case above, purchaser shall return the product to GloTech or a designated repair facility and prepay all freight charges.
- III. If GloTech confirms that the product is defective, then GloTech shall, at its sole discretion, provide the purchaser one of the following:
 - a. The returned product, repaired to factory specifications
 - b. Replacement product
 - c. Credit in the amount of the original product purchase from GloTech
- IV. During the entire two (2) year warranty, GloTech’s obligation as to repair or replacement shall further be limited to repair or replacement with the models of the meters that are available at the time of the repair or replacement and shall be limited to the repair or replacement of only the specific model that fails due to a manufacturing defect.
- V. Any repaired or replaced product shall also remain subject to the original two (2) year warranty from the date of the original purchase/installation, and any repair or replacement shall not extend the original warranty period in any manner or start a new warranty period.
- VI. This Limited Warranty does not cover product damage, defects, or failure due to:
 - a. Damage incurred during transportation, storage, or handling by the purchaser
 - b. Lack of proper installation or operation as outlined by the product Installation, Operation, and Maintenance Manual
 - c. Unauthorized modifications or repair to the product



- d. External causes such as accidents, abuse, neglect, or other actions or events beyond GloTech's reasonable control
 - e. Electrical current fluctuations
 - f. Decomposition from handling of abrasive/corrosive fluids not intended or approved for the specific model of product
 - g. Normal wear and tear of the product or components
- VII. Any repair of the product performed by the purchaser without prior written approval by GloTech shall void the Limited Warranty.
- VIII. This warranty covers only the product itself and does not include any costs associated with removal, uninstallation, reinstallation, site access, labor, travel, equipment rental, or any other field service expenses.

Disclaimer of Warranties

EXCEPT FOR THE WARRANTY OUTLINED ABOVE, GLOTECH MAKES NO OTHER WARRANTIES WITH RESPECT TO ITS METERS, WHETHER ORAL, WRITTEN, IMPLIED, OR STATUTORY, INCLUDING ANY (A) WARRANTY OF MERCHANTABILITY; OR (B) WARRANTY OF FITNESS FOR A PARTICULAR PURPOSE; WHETHER EXPRESSED OR IMPLIED BY LAW, COURSE OF DEALING, COURSE OF PERFORMANCE, USAGE OF TRADE, OR OTHERWISE. GLOTECH SHALL NOT BE LIABLE FOR ANY LOSS OF REVENUES OR PROFITS, INCURRED INCONVENIENCES OR EXPENSES, OR ANY OTHER CONSEQUENTIAL, INCIDENTAL, SPECIAL OR PUNITIVE DAMAGES OR LOSSES, WHETHER DIRECT OR INDIRECT, THAT IS CAUSED BY THE USE OR MISUSE, OR INABILITY TO USE ITS PRODUCTS.

Limitation of Liability

No claim by the buyer/owner of any kind, including claims for indemnification, shall be greater in amount than the purchase price of the Products in respect to which damages are claimed. IN NO EVENT SHALL GLOTECH BE LIABLE TO BUYER/OWNER IN TORT, CONTRACT OR OTHERWISE, FOR ANY SPECIAL, INDIRECT, INCIDENTAL, CONSEQUENTIAL, RELIANCE, STATUTORY, SPECIAL, PUNITIVE OR EXEMPLARY DAMAGES, INCLUDING, BUT NOT LIMITED TO, LOST PROFITS, LOSS OF USE, LOSS OF TIME, LOSS OF REVENUES, INCONVENIENCE, LOSS BUSINESS OPPORTUNITIES, DAMAGE TO GOOD WILL OR REPUTATION, OR LOSS OF DATA, EVEN IF ADVISED OF THE POSSIBILITY OF SUCH DAMAGES OR SUCH DAMAGES COULD HAVE BEEN REASONABLY FORESEEN, IN CONNECTION WITH, ARISING OUT OF, OR AS A RESULT OF, THE SALE, DELIVERY, SERVICING, USE OR LOSS OF USE OF THE PRODUCTS SOLD HEREUNDER, OR FOR ANY LIABILITY OF BUYER TO ANY THIRD PARTY WITH RESPECT THERETO.